

ADVANCED BEARING SOLUTIONS
FOR THE WIND INDUSTRY



SUBSCRIBE TO NSK NEWSLETTER 

SETTING THE FUTURE IN MOTION

We are among the leading manufacturers for rolling bearings, linear technology components and steering systems worldwide. We can be found on almost every continent – with production facilities, sales offices and technology centres – because our customers appreciate short decision-making channels, prompt deliveries and local service.

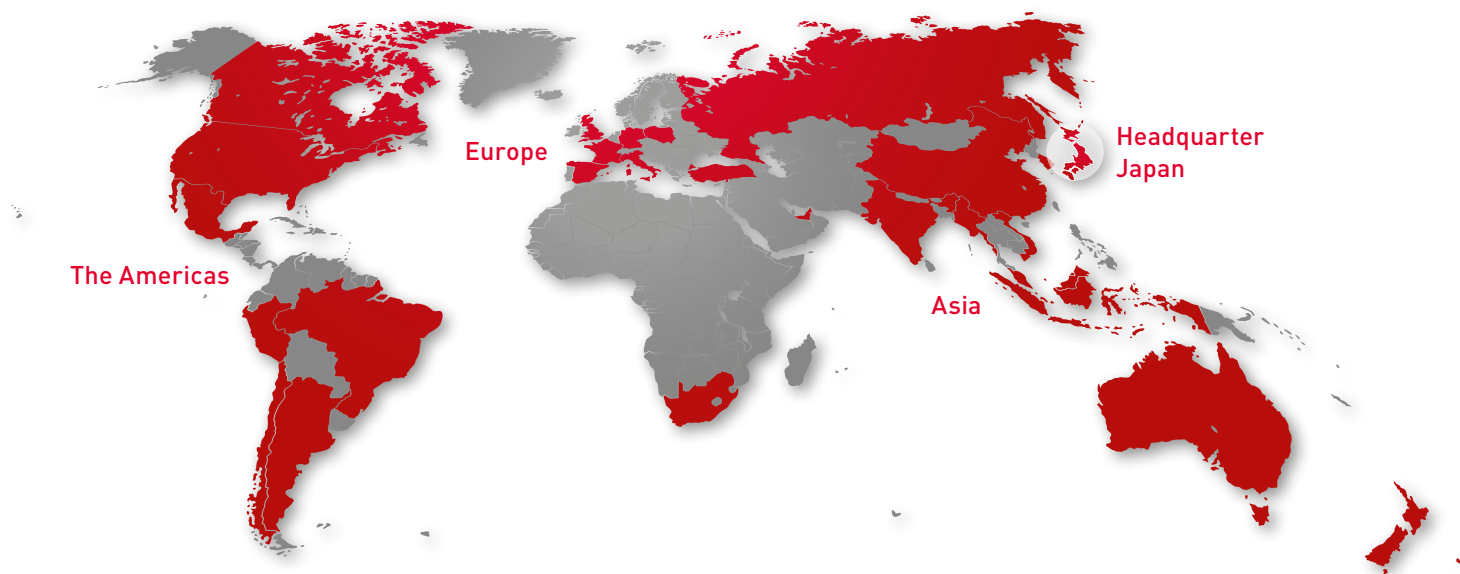

The NSK company

NSK commenced operations as the first Japanese manufacturer of rolling bearings back in 1916. Ever since, we have been continuously expanding and improving not only our product portfolio but also our range of services for various industrial sectors. In this context our worldwide research and production facilities are linked together in a global network. Here we concentrate not only on the

development of new technologies, but also on the continuous optimisation of quality – at every process stage. Among other things, our research activities include product design, simulation applications using a variety of analytical systems and the development of different steels and lubricants for rolling bearings.

Trademarks: All NSK product and service names listed in this catalogue are trademarks or registered trademarks of NSK Ltd.

OUR MOST IMPORTANT PRODUCT: OUR CUSTOMERS' SATISFACTION

One thing keeps us moving: we want to help you increase the reliability of your vehicles and equipment, not only with excellent products, but above all with excellent service. Our experienced engineers have a deep understanding of systems – together with you, they work to optimise products and processes and develop solutions for the future. The goal that we are dedicated to every day is ensuring that you remain competitive over the long run.

More about NSK on www.nskeurope.com



EVERY SOLUTION CALLS FOR THE RIGHT PRODUCTS

Whether for the main drive stage or accessories, our broad range of rolling bearing products deliver reliable and sustainable operating life for a wide variety of applications.

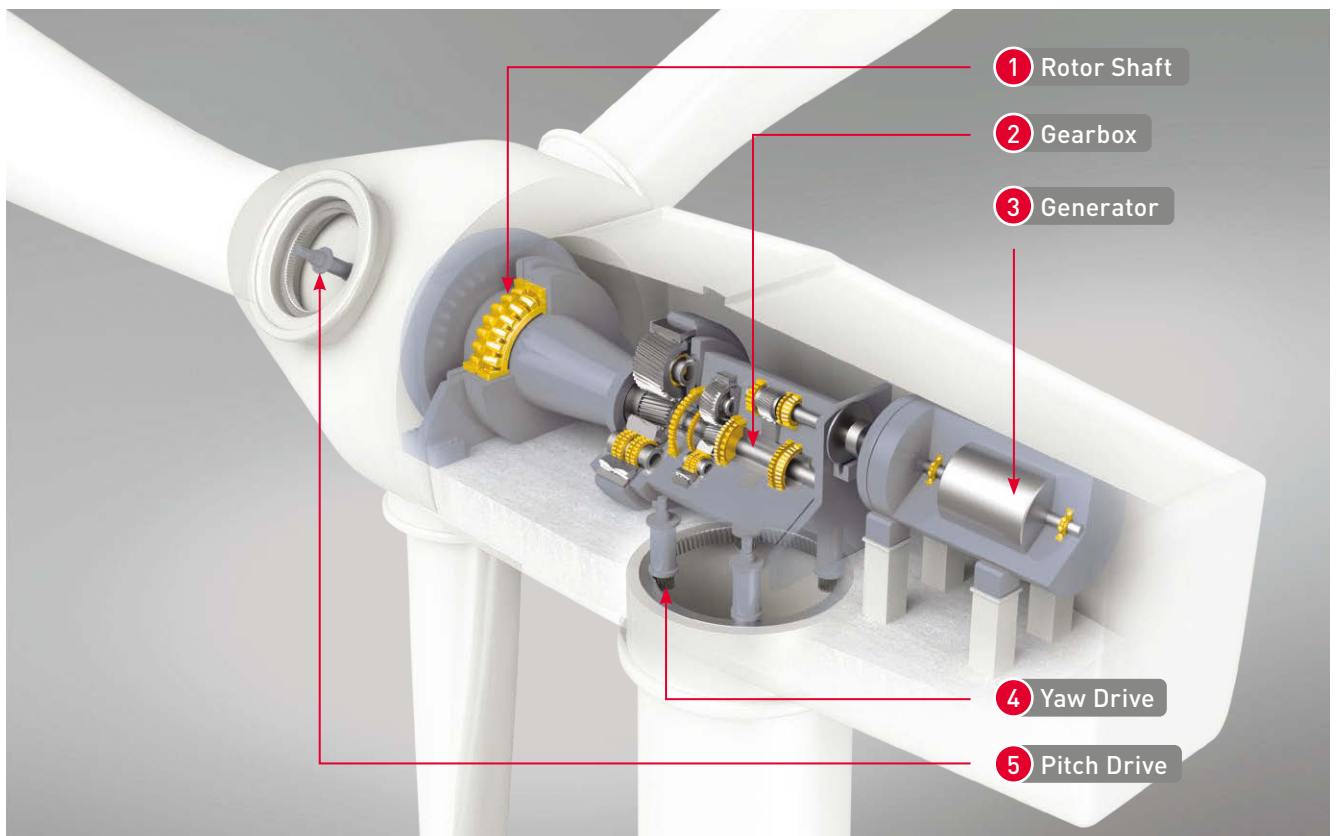

	Spherical Roller Bearings	Cylindrical Roller Bearings - Single Row	Cylindrical Roller Bearings - Double Row	Tapered Roller Bearings - Single Row	Tapered Roller Bearings - Double Row / Duplex	Deep Groove Ball Bearings	Four-Point Bearings
Rotor Shaft	■	■		■	■		
Gearbox	■	■	■	■	■	■	■
Generator		■				■	
Pitch / Yaw Gearbox	■	■		■		■	

Rotor Shaft

The rotor induces high axial and radial loads in the main bearings, which occur both statically and dynamically. Given such loads as these, high bearing stiffness is indispensable. Spherical roller bearings used in the 3 point drivetrains, or cylindrical and tapered roller bearings used in the modular drivetrain, are particularly well-suited for this application.

Gearbox

A variety of gearbox arrangements have been implemented for wind turbines in recent years. Megawatt-class systems often combine planet gear stage(s) with multiple parallel gear stages. Deep groove ball bearings, spherical roller bearings, cylindrical roller bearings, tapered roller bearings and four-point contact ball bearings are used, depending on the location of the bearing.

Generator

Generators primarily use deep groove ball bearings and cylindrical roller bearings. Transmission of electrical current can damage the rolling bearings and shorten their service life. In order to avoid this damage, the use of insulated rolling bearings should be considered. NSK offers coated rolling bearings where an insulating coating has been applied to the outer rings.

Pitch and Yaw Gearbox

Yaw gearboxes turn the nacelle into the wind or away from it. Pitch gearboxes are required for rotor blade adjustment. Deep groove ball bearings, cylindrical roller bearings, spherical roller bearings and tapered roller bearings are typically installed in these gearboxes.

Black Oxide Coating (BOC)

Black oxide coating is an effective surface treatment to counteract bearing damage due to slip-page that occurs typically during start-up. It can be used in all main gearbox bearing locations for optimum protection and performance.

Falex Test

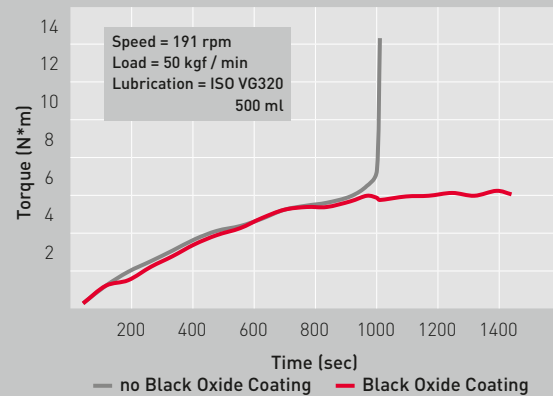

MAIN SHAFT BEARINGS

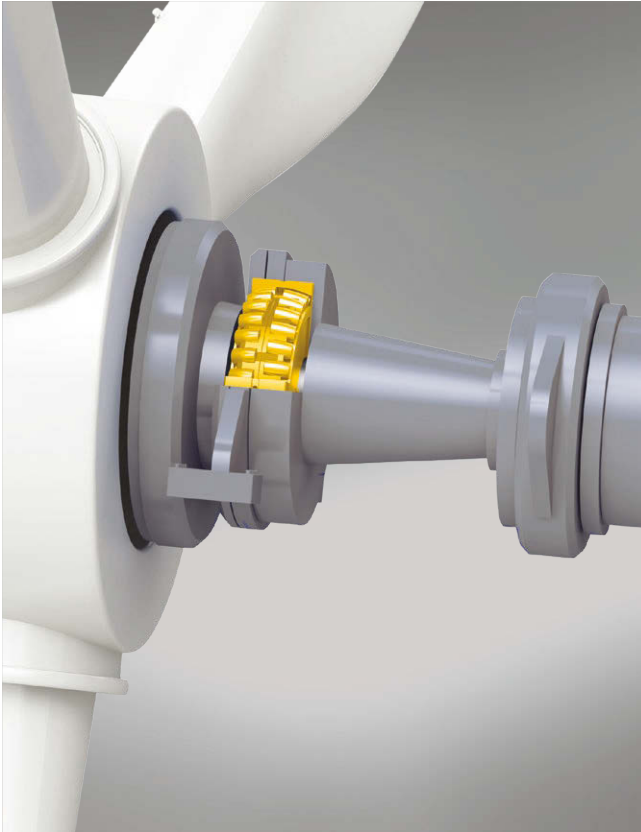

3-Point Suspension

One of the most common wind turbine architectures is the 3-point suspension. In this configuration, a single main spherical roller bearing is used to support the main shaft and wind loading. The other end of the main shaft is rigidly mounted to the input shaft of the gearbox and relies on the gearbox's flexible trunion system to share the loading through the gearbox's input shaft bearings. All of the wind loading generated by the rotor, as well as its torque, must be safely transmitted through the gearbox structure and mounting system to the wind turbine's frame.

Bearing Selection: Spherical Roller Bearing
CA Design

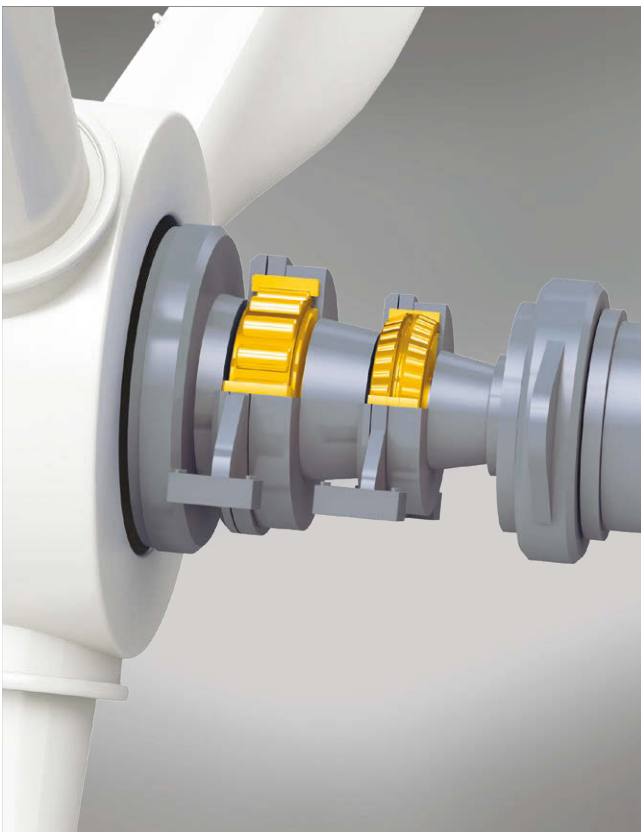

4-Point Suspension

The modular drivetrain architecture is a typical configuration consisting of two main bearings that support a separate main shaft. This main shaft is also rigidly connected to the gearbox input shaft. The bearings supporting the main shaft isolate the wind loading from the gearbox and its bearings. Only deflections and tolerances may cause additional reaction loads in the gearbox bearings. Often the reaction loads at the bearings cannot easily be calculated in this statically indeterminate drivetrain configuration.

Bearing Selection: Tapered Roller Bearing
Single Row or
Double Row KDH or
KH Design
Cylindrical Roller Bearing
Single Row NU, NJ or NF Design



Spherical Roller Bearings CA Design

CA series spherical roller bearings with heavy duty machined brass cage have extremely high load capacity and superior durability. With optimized internal geometry, they are especially suitable for applications with heavy loads, shock conditions and misalignment, delivering high performance in large rotor shaft arrangements even at low speeds. Available with Super-TF long-life steel.



Tapered Roller Bearings Double Row

NSK double-row tapered roller bearings are designed with a single inner ring, 2 roller/cage sets and 2 outer rings with spacer. Optimized large-size rollers guided by high strength, wear resistant cages deliver high capacity for combined heavy radial loads and axial loads in both directions. In inch and metric dimensions with normal contact angle (KH design) or with steep angle races (KDH design) for increased axial load capacity. Available with Super-TF long-life steel.

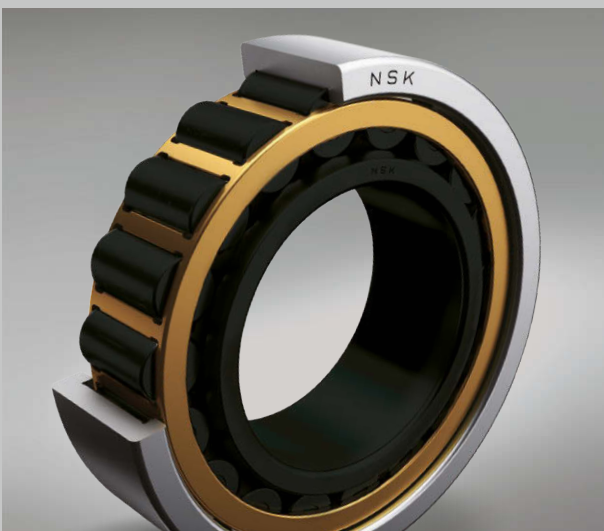

Cylindrical Roller Bearings Single Row

Optimized size and profile of rollers guided by high precision machined cages deliver higher load ratings and smooth rotation in main shaft applications, even at very low speeds. With heavy duty precision machined brass cage or pin-type cages. Available with Super-TF long-life steel.

MAIN GEARBOX BEARINGS

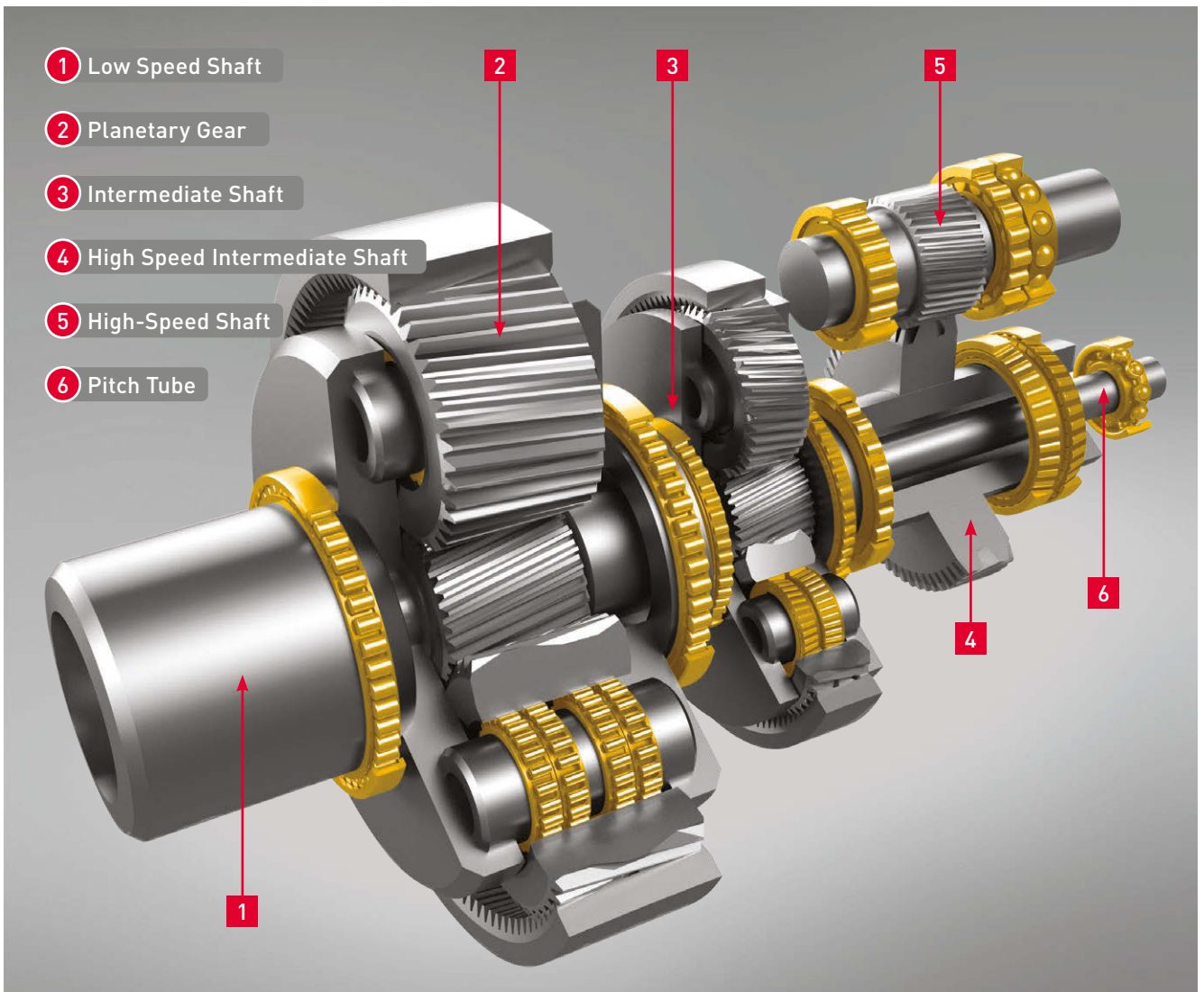

Cylindrical Roller Bearings NSKHPS, EM Cage

- Bearing life increased as much as 2x compared to conventional designs
- As much as 23% higher basic load rating
- High strength and maximum rigidity for high loads and high speeds
- Higher permissible misalignment

	Cr	Life	Permissible Misalignment	
			22XXE, 23XXE	2XXE, 3XXE
Conventional	1	1	2'	4'
NSKHPS	1.23	2	4'	4'

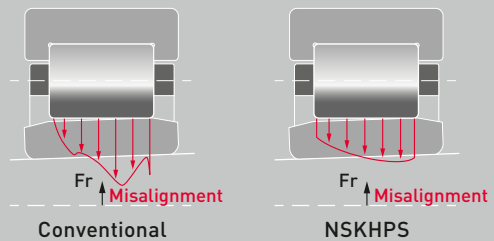

Through close collaboration with our wind industry partners, NSK has gained tremendous insight into the complex conditions that impact wind turbine operation – none more profoundly than within the gearbox. Our advanced product development takes into consideration

the continuous variation and fluctuation of factors such as lubrication, loads, stresses, vibrations and temperatures to deliver reliable and cost-effective operating life.



Cylindrical Roller Bearings, full complement

Cage-less full complement cylindrical roller bearings have the maximum possible number of rollers and can sustain much heavier loads than cylindrical roller bearings of the same size with cages. In single row NCF and double row NNCF series. Available with Super-TF long-life steel and black oxide coating.

**Bearing Location: Planetary Carrier
Planetary Gear**

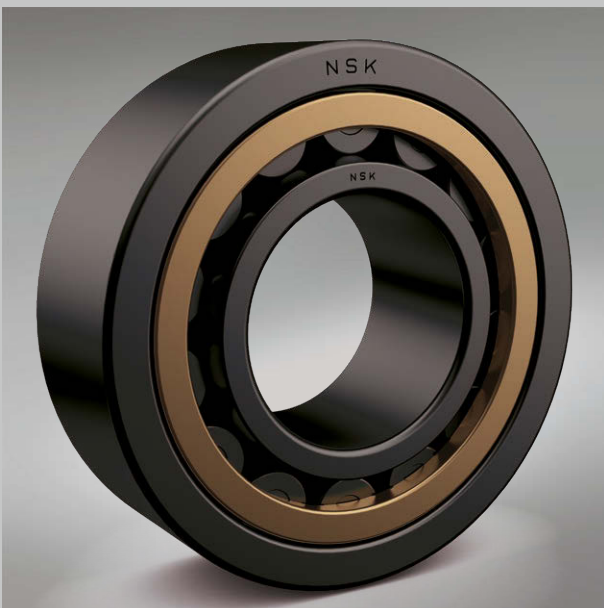

Cylindrical Roller Bearings, single row

Featuring NSKHPS high performance standard for increased load capacity and speed ratings, NSK single row cylindrical roller bearings deliver high strength and radial rigidity for high loads and speeds. Optimized internal geometry promotes lower running temperature and quiet operation. Available with AWS-TF long-life steel specialized to prevent white etching cracks. Also available with Super-TF long-life steel and black oxide coating.

**Bearing Location: High-Speed Intermediate Shaft
High-Speed Shaft
Planetary Gear**

MAIN GEARBOX BEARINGS



Four Point Contact Ball Bearings

Four-point ball bearings are designed with a 35° contact angle and an inner ring that is split radially into two pieces. Cage is machined brass. Their design allows one bearing to sustain significant axial loads in either direction with high capacity. They are capable of accommodating pure axial loads or combined loads where the axial load is higher. Available with Super-TF long-life steel and black oxide coating.

**Bearing Location: High-Speed Intermediate Shaft*
High-Speed Shaft***

*only MRO business



Deep Groove Ball Bearings

NSK Deep Groove Ball Bearings are designed to deliver unsurpassed performance for a wide variety of applications. Precision high-grade balls and super-finished raceways provide smooth and quiet operation. For low to medium radial loads and smaller axial loads in both directions. Advanced lubricant technology and sealing designs ensure optimum performance and reliability. Available in NSKHPS series with pressed steel cage or machined brass cage.

Bearing Location: Pitch Tube

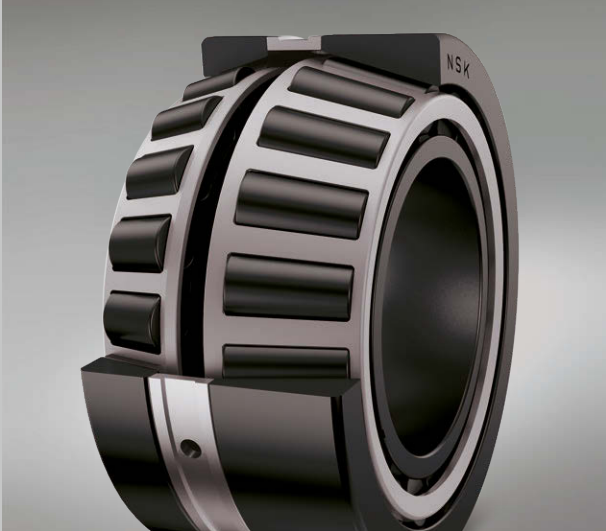

Tapered Roller Bearings, duplex

Duplex tapered roller bearing arrangements feature two single row bearings and an outer ring spacer, as equivalent singles or as a major/minor set. They can accommodate heavy radial loads and axial loads in both directions. Available with Super-TF long-life steel or AWS-TF long-life steel specialized to prevent white structure flaking. Also available with black oxide coating.

Bearing Location: High-Speed Intermediate Shaft
High-Speed Shaft
Low-Speed Intermediate Shaft



Tapered Roller Bearings, single row

Single row tapered roller bearings have high radial and axial rigidity, and are capable of taking high radial loads and moment loads as well as axial loads in one direction. NSK offers a range of large size, dimensionally specialized single row tapered roller bearings for main gearbox applications in both metric and inch configurations. Available with Super-TF long-life steel and black oxide coating.

Bearing Location: Planetary Carrier
High-Speed Intermediate Shaft
High-Speed Shaft



Tapered Roller Bearings, double row

Double row tapered roller bearings feature two roller/cage sets and two outer rings with spacer on a single inner ring. They can accommodate heavy radial loads and axial loads in both directions. Available in normal contact angle (KH design) or with steep angle races (KDH design) for increased axial load capacity. Available with Super-TF long-life steel and black oxide coating. Also available as integrated bearings for planetary gears without outer ring

Bearing Location: Low-Speed Intermediate Shaft
High-Speed Intermediate Shaft
High-Speed Shaft

GENERATOR BEARINGS

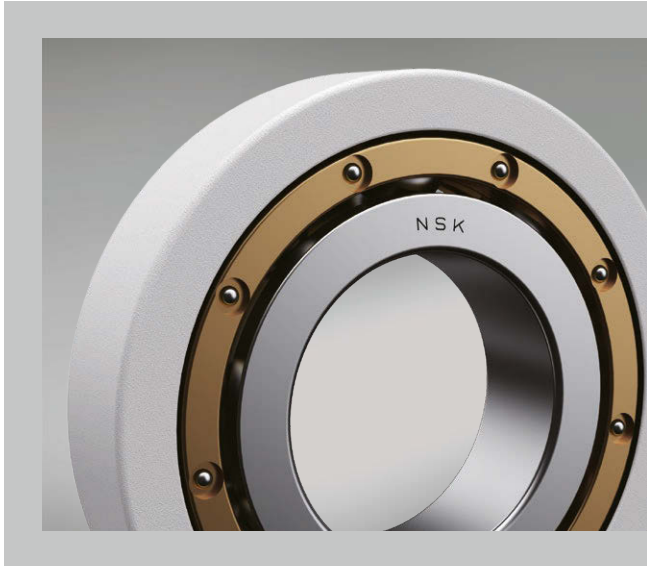

Ceramic Coated Insulating Bearings

NSK ceramic coated bearings provide superior insulation properties to prevent electrical erosion or arcing in bearings used in turbine generators. An optimized alumina-based ceramic material combined with a blend of additives is used to coat the outer ring, offering a high resistance to the flow of electrical current. The coating is tough and durable when impacted on its corner surfaces, and possesses excellent heat dissipation properties. Boundary dimensions are identical to a standard bearing, enabling easy replacement without need for modifications.

Bearing Location: Generator

Specification	NSK Ceramic Insulation HD2
Application	Generator
Insulating material	Al2O3
Insulation resistance (1000VDC)	Over 100MΩ
Breakdown voltage	Over 4kV
Boundary dimension	ISO standard

NSK has also Ceramic Balls for isolation purposes.

ADVANCED SOLUTIONS – NSK TOUGH STEEL

The valuation of a wind turbine includes one major maintenance cycle during its 20-year life expectancy. As such, the need for improved durability in bearing performance is a critical consideration to achieve the greatest reliability and total cost performance – even in uniquely demanding operating conditions. In response, NSK has applied our Tough Steel technology to develop bearing solutions that set a new standard for long service life.

NSK's Super-TF (STF) series bearings are designed to deliver outstanding durability in operating environments subject to contamination. Utilizing advanced material engineering and heat treatment technology, they perform with superior resistance to wear and seizure under contaminated lubrication conditions. For the specific challenge of hydrogen induced embrittlement impacting bearings used in turbine gearboxes, NSK has introduced our AWS-TF technology to attack premature bearing failure at the core of its generation: the metallurgy.

Outstanding toughness, performance, and total cost-savings: NSK technology sets a new standard for long service life.



SUPER TF AND AWS-TF BEARINGS

In its quest for longer bearing service life, NSK has spent many years analyzing the mechanisms of fatigue in bearings and researching and developing materials, heat treatment processes and operating conditions. The range of approaches to achieving longer service life taken by our research team are shown in Fig. 1. The technology incorporated in our AWS-TF and Super-TF Bearings is designed to maximize service life under conditions where bearings are subject to hydrogen induced embrittlement and contamination induced surface-originating flaking.

Goal: Longer service life

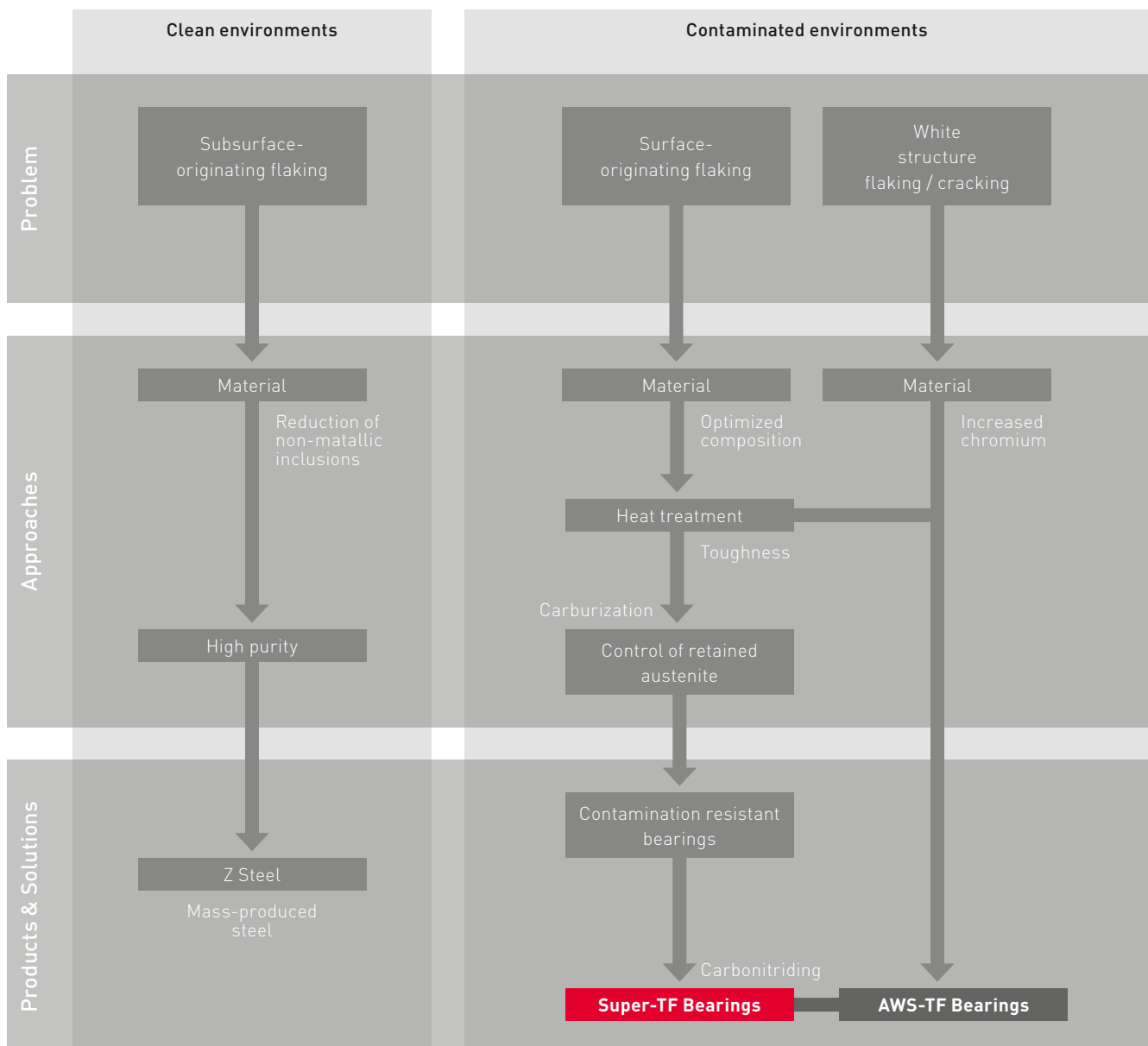

Fig.1 Approaches to achieving longer service life from bearings

SUPER TF AND AWS-TF BEARINGS

Super-TF and surface – Originating flaking

Bearings can be required to operate under conditions where lubrication is easily contaminated. Metal particles or casting sand in the lubricant create dents in the rolling contact surfaces, and stress concentrated around these dents eventually leads to cracking and to surface-originating flaking. The ability to reduce the concentration of stress around the shoulders of surface dents is directly related to achieving longer service life from the bearing.

NSK research and development of material properties has revealed that a high level of retained austenite is an extremely effective means of maximizing the r/c value – where “ r ” is the radius at the shoulder of the dent and “ $2c$ ” is the shoulder to shoulder width – around surface dents in the bearing material (see Fig. 2). The greater the r/c value, the smaller the stress concentration. TF technology in general is a unique heat treatment pro-

cess developed by NSK to optimize the level of retained austenite in bearing materials.

However, austenite itself has a soft microstructure, reducing the hardness of the bearing material. To meet the needs for greater hardness with a higher level of retained austenite, NSK adopts a technique to promote the uniform distribution and reduce the diameter of carbide and carbonitride particles in the bearing material. Super-TF bearing steel contains appropriate amounts of chrome and molybdenum to optimize the formation of carbides.

Figures 3 and 4 illustrate that Super-TF Bearings have a greater amount of fine-size carbide and carbonitride particles than ordinary carburized bearings, giving them a greater degree of hardness and higher retained austenite for a long service life.

Fig. 2 Relationship of r/c value to retained austenite level

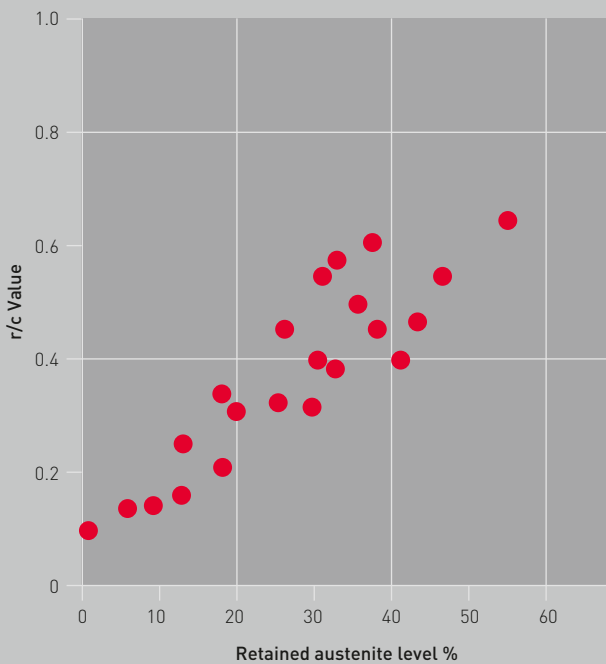
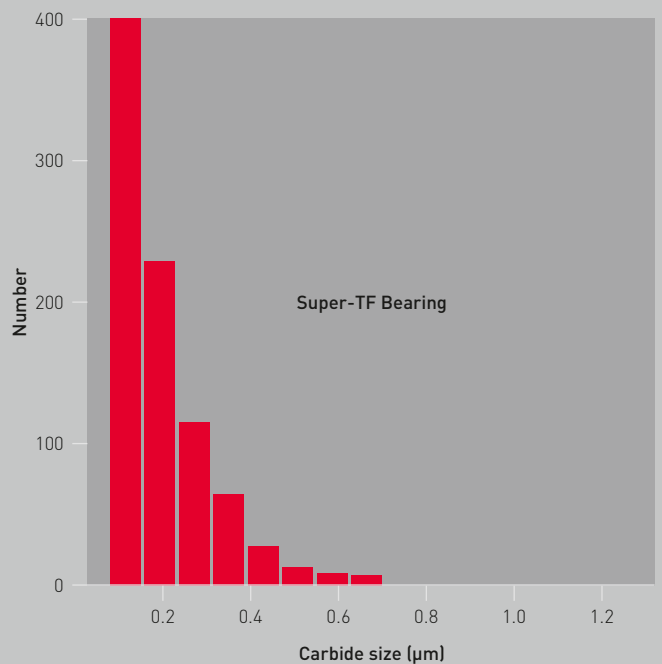

Fig. 3 Average diameter of carbide and carbonitride particles in a Super-TF Bearing



AWS-TF and white structure flaking

Hydrogen embrittlement is a prevailing bearing failure mode found in wind turbine applications. It is a process by which hydrogen penetrates into the bearing steel, causing it to weaken. Hydrogen itself is generated by typical tribomechanical and tribochemical events occurring to the bearing lubricant during operation of the wind turbine. White structure forms below the surface of the bearing, and this change to the microstructure results in the formation of cracks that will extend to the surface of the bearing under stress concentration during operation. Cracks propagate under the load of each passing roller, leading to flaking and ultimately bearing failure.

With our AWS-TF bearings, NSK has countered white structure flaking by applying the technology of Tough Steel long-life materials. White structure flaking tends to be generated when hydrogen becomes concentrated

at stress points. NSK optimizes additional chromium content in our bearing steel composition to significantly decrease the diffusion rate of hydrogen and delay microstructural change, thereby increasing resistance to white structure flaking. In rolling fatigue life tests conducted in hydrogen charged environments, increasing chromium content proves to ensure longer life performance.

Fig. 4 Average diameter of carbide particles in an ordinary carburized steel bearing

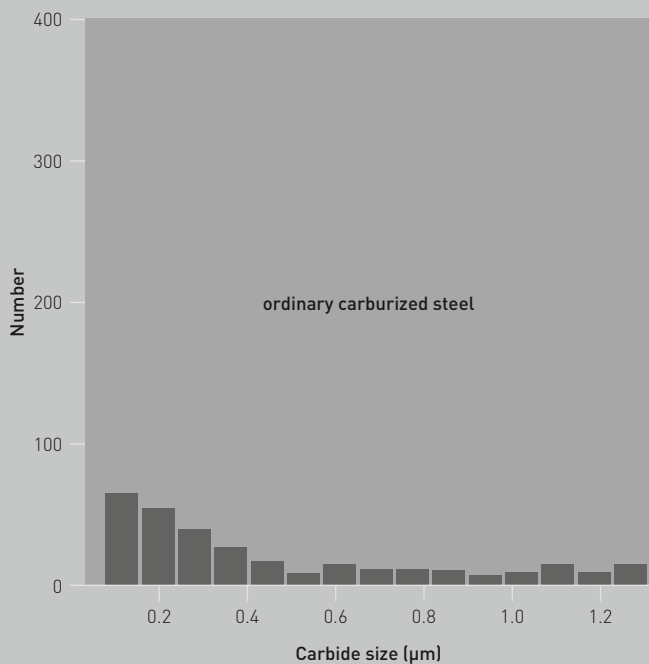

BEARING FAILURE MODES

Surface-originating flaking



Location:
Gearbox - All
Bearing Positions
Main Shaft

Solution:
Super-TF (STF)
Long-life Steel

Comparison of service life

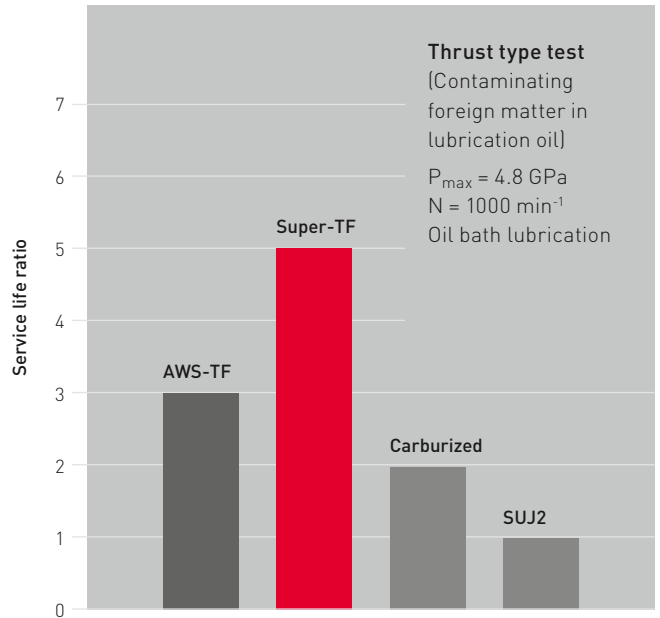

STF delivers 5 times the life of standard steel (SUJ2), while AWS-TF delivers 3 times

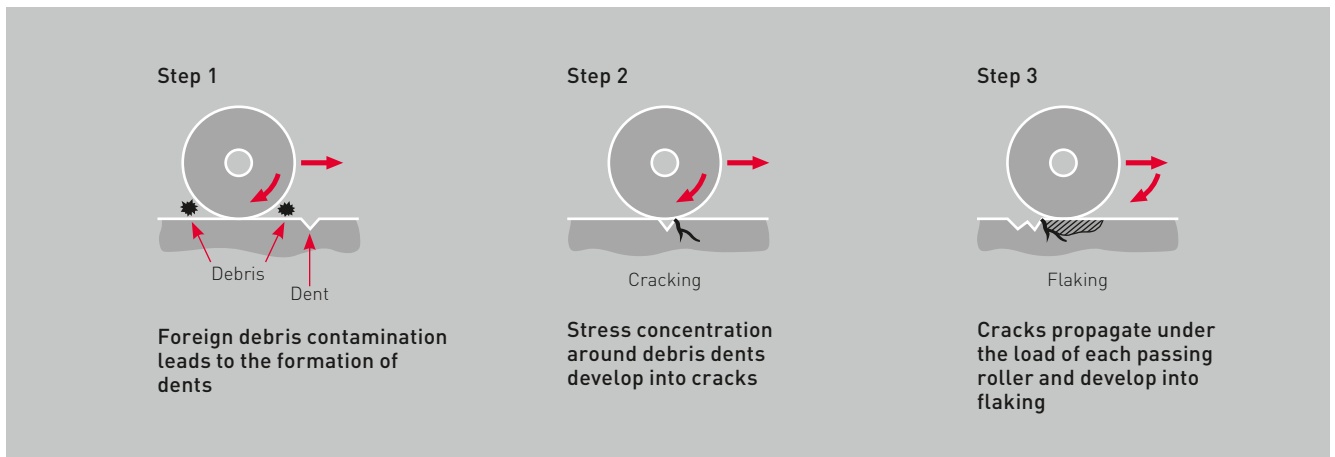

Skidding

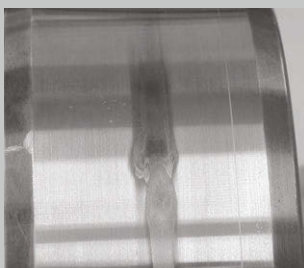

Location:
Gearbox - LSS,
HSIMS, HSS

Solution:
Black oxide coating

Electrical erosion



Location:
Generator - rotor
bearing

Solution:
Ceramic coating

White etching cracks / flaking



Location:
Gearbox - HSIMS, HSS

Solution:
Anti-White Structure
TF (AWS-TF)
Long-life Steel

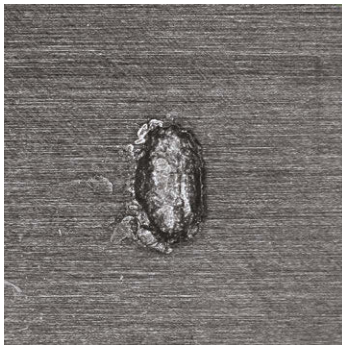

Comparison of service life

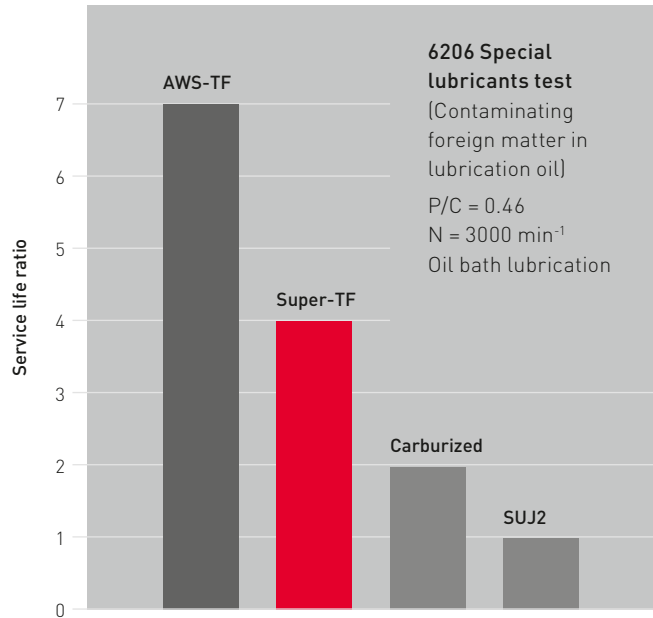

AWS-TF delivers 7 times the life of standard steel [SUJ2], while STF delivers 4 times

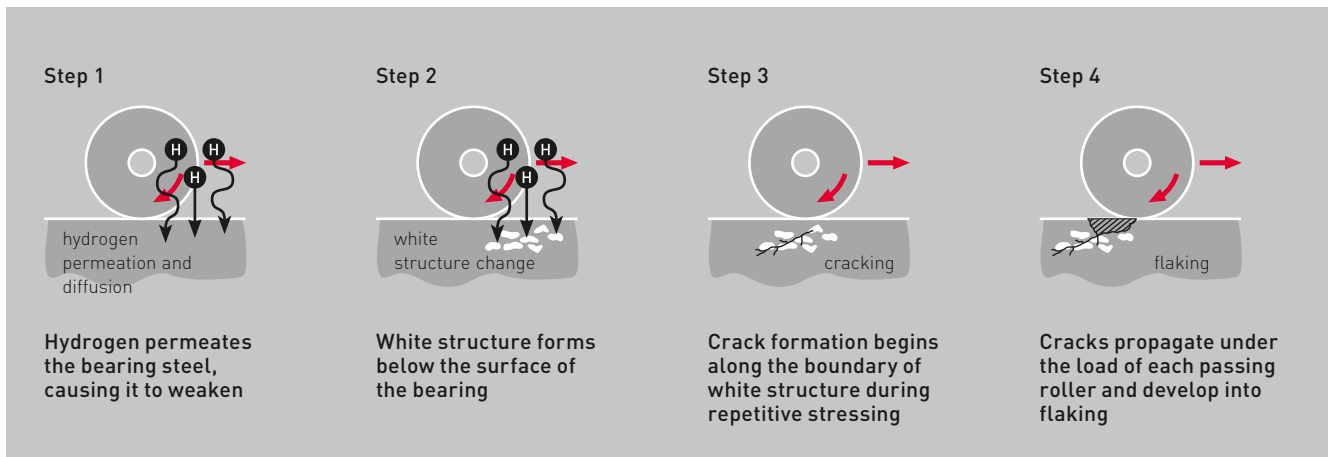

Adhesive wear



Location:
Main Shaft - 3 point suspension
Planetary Carrier, Planet Gear

Solution:
Super-TF (STF) Long-life Steel
Black oxide coating

EXAMPLES: BEARING NOMENCLATURE

Spherical Roller Bearing - 3 PT Suspension

STF 240 /600 g5 -01 U303

- STF** Super-TF long-life steel
- 240** spherical roller bearing, width series 4, diameter series 0
- /600** bore diameter equals 600 mm
- g5** STF on inner and outer ring
- 01** high capacity internal design
- U303** special process control for wind turbines

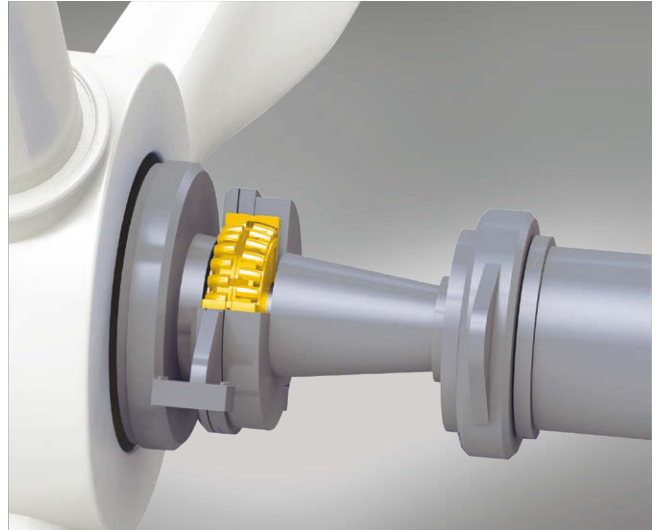

Cylindrical Roller Bearing - modular drivetrain

STF NJ 28 /710 g5 U303

- STF** Super-TF long-life steel
- NJ** single row cylindrical roller bearing - 2 outer ring ribs, one inner ring rib
- 28** dimension series (width series 2, diameter series 8)
- /710** bore diameter equals 710 mm
- g5** STF on inner and outer ring
- U303** special process control for wind turbines

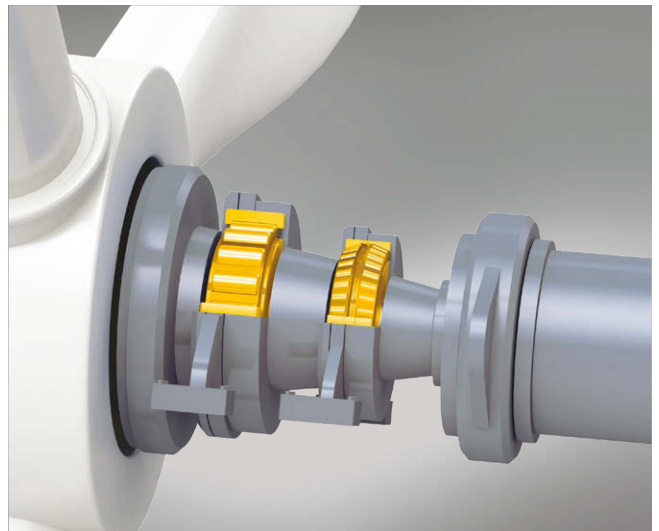

Tapered Roller Bearing, double row - modular drivetrain

STF 460 KDH 65 01 g5 U303

- STF** Super-TF long-life steel
- 460** bore diameter equals 460 - 460.999 mm
- KDH** double row tapered roller bearing, steep angle race
- 65** outer diameter equals 650 - 650.999 mm
- 01** tolerance for metric bearing
- g5** STF on inner and outer ring
- U303** special process control for wind turbines

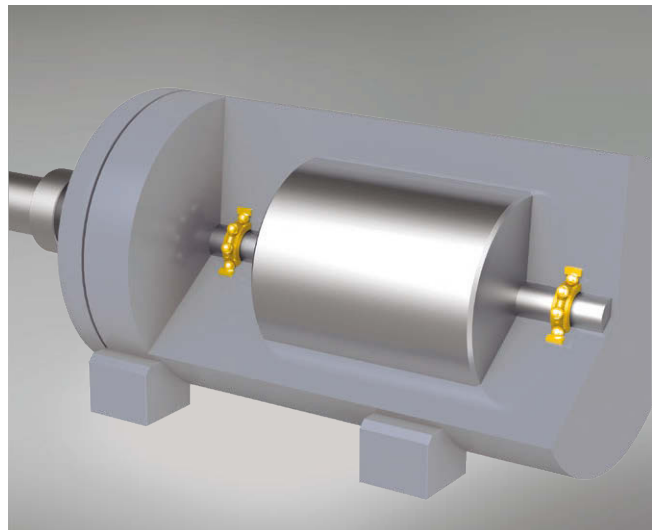

Cylindrical Roller Bearing, single row – HSIMS, HSS

NU 23 26 A /S/ U303

- NU** single row cylindrical roller bearing - 2 outer ring ribs, no inner ring ribs
- 23** dimension series (width series 2, diameter series 3)
- 26** Special wear resistant material designation
- A** design number
- /S/** black oxide coating
- U303** special process control for wind turbines

Deep Groove Ball Bearing – Conduit Tube

26 DDU C3 & AS2S

- 60** single row deep groove ball bearing dimension series 0
- 26** bore diameter equals 130 mm (reference number x 5)
- DDU** contact seals (non-contact seals and shielded closures available)
- C3** greater than normal radial internal clearance
- &** NSKHPS symbol - High Performance Standard
- AS2S** grease type and fill

Tapered Roller Bearing, single row – carrier support

R 431Z -3 /S/ U303

- R** single row tapered roller bearing, special dimensions
- 431Z** bore diameter equals 431 - 431.999 mm
- 3** serial number
- /S/** black oxide coating
- U303** special process control for wind turbines

Cylindrical Roller Bearing, full complement – planetary carrier and gear

NNCF 50 44 /S/ DR

- NNCF** full complement cylindrical roller bearing, double row
- 50** dimension series (width series 5, diameter series 0)
- 44** bore diameter equals 220 mm (reference number x 5)
- /S/** black oxide coating
- DR** controlled size variation arrangement
- U303** special process control for wind turbines

Four Point Contact Ball Bearing – HSIMS, HSS

QJ 3 28 U303

- QJ** four point contact ball bearing
- 3** dimension series 3
- 28** bore diameter equals 140 mm (reference number x 5)
- U303** special process control for wind turbines

Deep Groove Ball Bearing, Ceramic Coated – Generator

63 30 HDY2 U303

- 63** deep groove ball bearing, diameter series 3
- 30** bore diameter equals 150 mm (reference number x 5)
- HDY2** ceramic coated outer ring)
- U303** special process control for wind turbines

Tapered Roller Bearing, double row – LSS

431 KH 57 55 U303

- 431** bore diameter equals 431 - 431.999 mm
- KH** double row tapered roller bearing
- 57** outer diameter equals 570 - 570.999 mm
- 55** tolerance for inch bearing
- U303** special process control for wind turbines

Tapered Roller Bearing, duplex – HSIMS, HSS, LSIMS

HR 303 26 J AWS g5 / HR 313 26 J DF

+ KR C3 U303

- HR** High load
- 303** medium width series 0, diameter series 3
- 26** bore diameter equals 130 mm (reference number x 5)
- J** According to ISO
- AWS** AWS-TF long-life steel, specially developed to prevent white etching cracks
- g5** AWS applied to inner and outer ring
- 313** steep angle width series 1, diameter series 3
- DF** Face to face arrangement
- KR** Spacer (Clearance controlled by Spacer width)
- C3** Clearance
- U303** special process control for wind turbines

NSK Sales Offices – Europe, Middle East and Africa

UK

NSK UK Ltd.
Northern Road, Newark
Nottinghamshire NG24 2JF
Tel. +44 (0) 1636 605123
Fax +44 (0) 1636 643276
info-uk@nsk.com

France

NSK France S.A.S.
Quartier de l'Europe
2, rue Georges Guynemer
78283 Guyancourt Cedex
Tel. +33 (0) 1 30573939
Fax +33 (0) 1 30570001
info-fr@nsk.com

Germany, Austria, Benelux, Switzerland, Nordic

NSK Deutschland GmbH
Harkortstraße 15
40880 Ratingen
Tel. +49 (0) 2102 4810
Fax +49 (0) 2102 4812290
info-de@nsk.com

Italy

NSK Italia S.p.A.
Via Garibaldi, 215
20024 Garbagnate
Milanese (MI)
Tel. +39 02 995 191
Fax +39 02 990 25 778
info-it@nsk.com

Middle East

NSK Bearings Gulf Trading Co.
JAFZA View 19, Floor 24 Office 2/3
Jebel Ali Downtown,
PO Box 262163
Dubai, UAE
Tel. +971 (0) 4 804 8205
Fax +971 (0) 4 884 7227
info-me@nsk.com

Poland & CEE

NSK Polska Sp. z o.o.
Warsaw Branch
Ul. Migdałowa 4/73
02-796 Warszawa
Tel. +48 22 645 15 25
Fax +48 22 645 15 29
info-pl@nsk.com

Russia

NSK Polska Sp. z o.o.
Russian Branch
Office I 703, Bldg 29,
18th Line of Vasilievskiy Ostrov,
Saint-Petersburg, 199178
Tel. +7 812 3325071
Fax +7 812 3325072
info-ru@nsk.com

South Africa

NSK South Africa (Pty) Ltd.
25 Galaxy Avenue
Linbro Business Park
Sandton 2146
Tel. +27 (011) 458 3600
Fax +27 (011) 458 3608
nsk-sa@nsk.com

Spain

NSK Spain, S.A.
C/ Tarragona, 161 Cuerpo Bajo
2ª Planta, 08014 Barcelona
Tel. +34 93 2892763
Fax +34 93 4335776
info-es@nsk.com

Turkey

NSK Rulmanları Orta Doğu Tic. Ltd. Şti.
Cevizli Mah. D-100 Güney Yan Yol
Kuriş Kule İş Merkezi No:2 Kat:4
Kartal - İstanbul
Tel. +90 216 5000 675
Fax +90 216 5000 676
turkey@nsk.com

Please also visit our website: www.nskeurope.com

Global NSK: www.nsk.com

